

Standard	Test Report No. / Report N°	CS22-0083295-02	Chapter / Capitolo	T11
EN 303-5:2012	Issued on / Emesso il	25.11.2022		
	Test engineer / Tecnico	Luca Pizzolato		

Technical Information

Informazioni Tecniche

Standard	Test Report No. / Report N°	CS22-0083295-02	Chapter / Capitolo	TI1
EN 303-5:2012	Issued on / Emesso il	25.11.2022		

Chapter "Technical information" consists of

Il capitolo "Informazioni tecniche" è costituito da

Title <i>Titolo</i>	Sub-chapter <i>Sottocapitolo</i>	Index of pages <i>Indice delle pagine</i>	
Family appliances - Boilers photos and description <i>Famiglia apparecchi - Foto delle caldaie e descrizione</i>	PH	from / da	3
		to / a	5
Family appliances - Technical data - Nominal heat output <i>Famiglia apparecchi - Dati tecnici - Potenza termica nominale</i>	TDN	from / da	6
		to / a	7
Family appliances - Technical data - Reduced heat output <i>Famiglia apparecchi - Dati tecnici - Potenza termica ridotta</i>	TDR	from / da	8
		to / a	9
Remarks and notes <i>Osservazioni e note</i>	RN	from / da	10
		to / a	10
----	----	from / da	----
		to / a	----
----	----	from / da	----
		to / a	----
----	----	from / da	----
		to / a	----
----	----	from / da	----
		to / a	----
----	----	from / da	----
		to / a	----

Attachment provided by the applicant/manufacturer <i>Allegato redatto dal richiedente/costruttore</i>	Annex to <i>Allegato a</i>	Number of pages <i>Numero di pagine</i>
Technical product sheet of the appliance(s) <i>Scheda/e tecnica/he dell'/degli apparecchio/i</i>	TI1	6
----	----	----
----	----	----
----	----	----
----	----	----

Note / Note

Every tests present in this Chapter performed by IMQ S.p.A. are covered by Accredia accreditation

Ogni prova condotta da IMQ S.p.A. presente in questo Capitolo, è coperta da accreditamento ACCREDIA

Standard	Test Report No. / Report N°	CS22-0083295-02	Chapter / Capitolo	T11
EN 303-5:2012	Issued on / Emesso il	25.11.2022	Subchapter / Sottocapitolo	PH

Photos of the appliance/s

Foto degli/dell'apparecchio/i

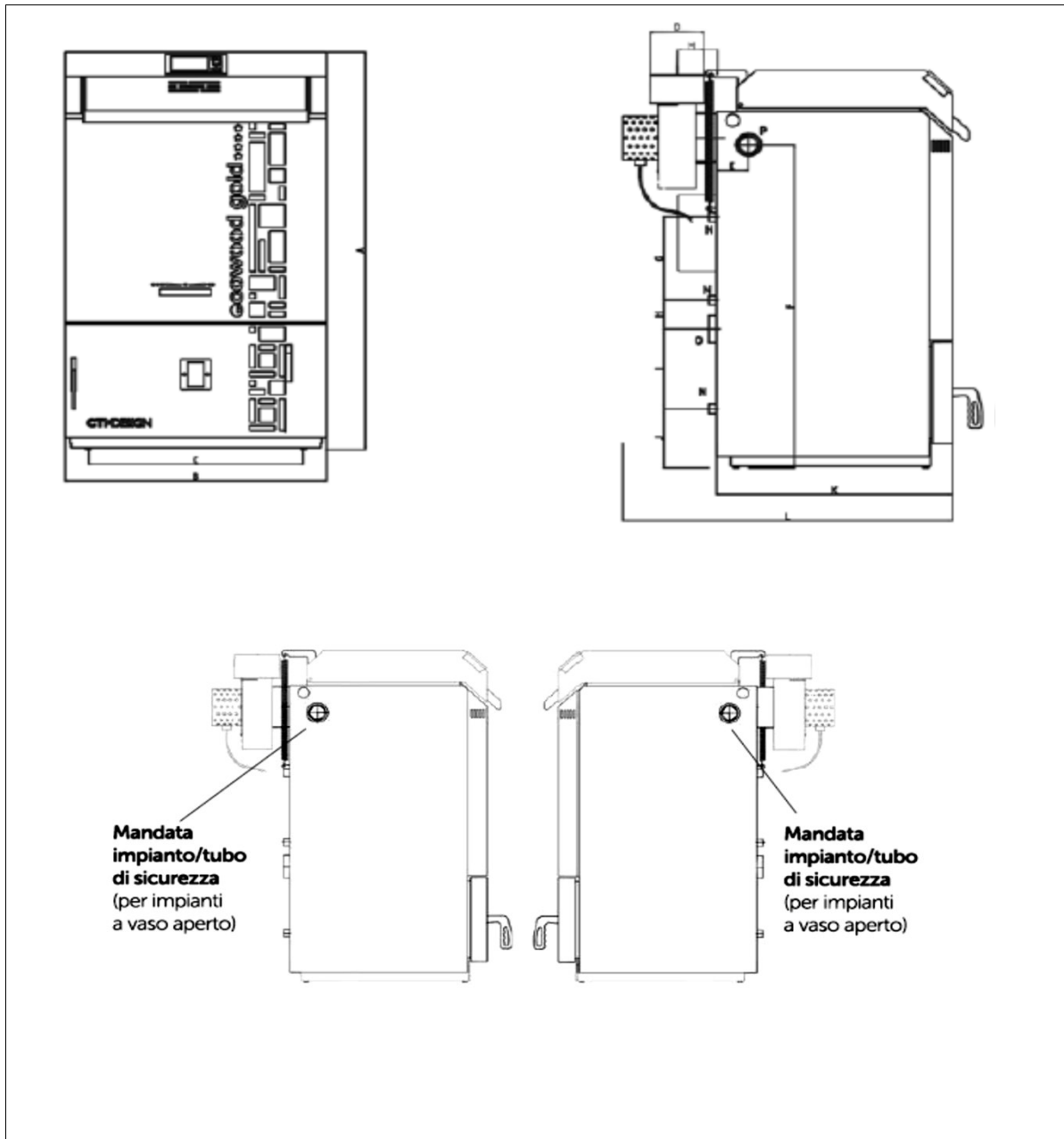

Model: Ecowood Gold 26

Description / Descrizione

Some details of the appliance

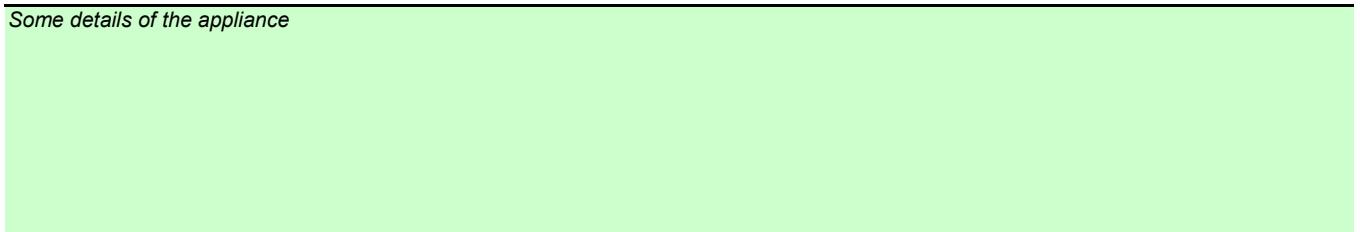

Standard	Test Report No. / Report N°	CS22-0083295-02	Chapter / Capitolo	T11
EN 303-5:2012	Issued on / Emesso il	25.11.2022	Subchapter / Sottocapitolo	PH

Photos of the appliance/s

Foto degli/dell'apparecchio/i

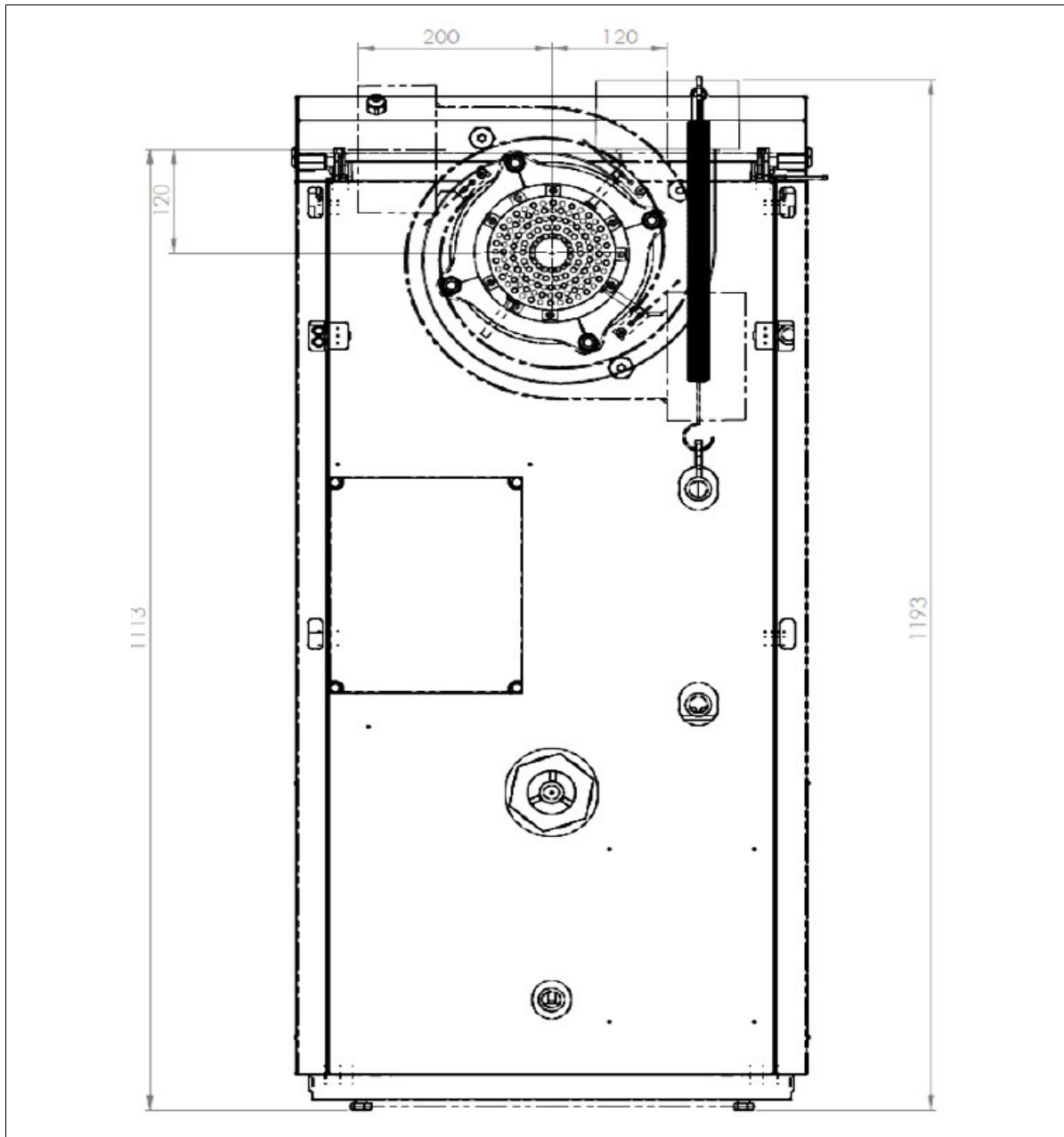

Model: Ecowood Gold 26

Description / Descrizione

Some details of the appliance

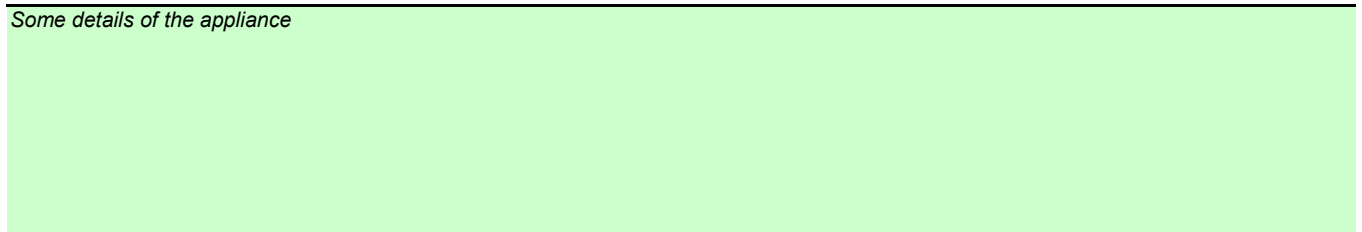

Standard	Test Report No. / Report N°	CS22-0083295-02	Chapter / Capitolo	T11
EN 303-5:2012	Issued on / Emesso il	25.11.2022	Subchapter / Sottocapitolo	PH

Photos of the appliance/s

Foto degli/dell'apparecchio/i

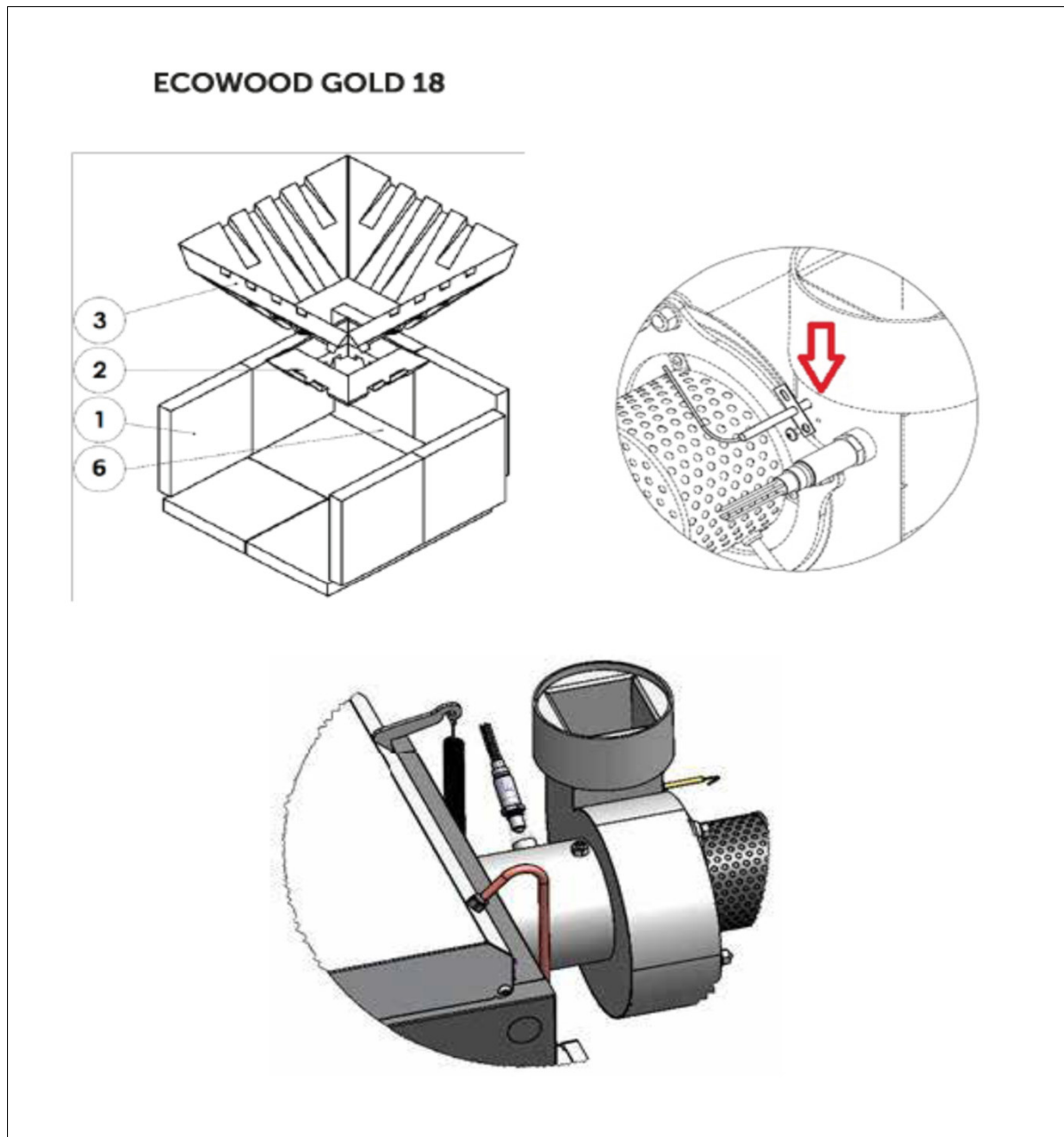

Model: Ecowood Gold 26

Description / Descrizione

Some details of the appliance

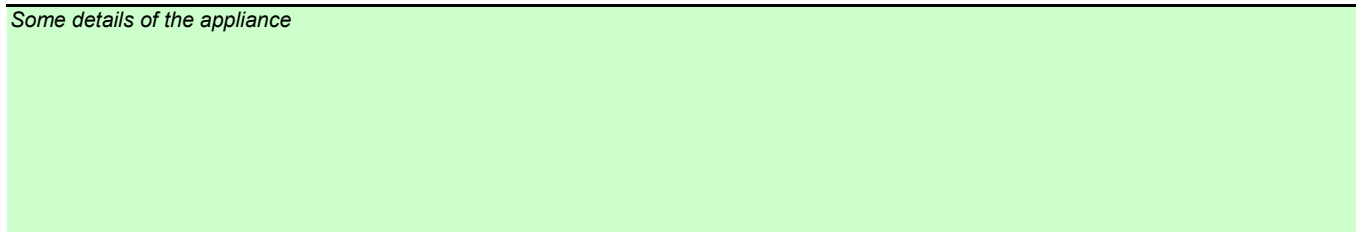

Standard	Test Report No. / Report N°	CS22-0083295-02	Chapter / Capitolo	TI1
EN 303-5:2012	Issued on / Emesso il	25.11.2022	Subchapter / Sottocapitolo	TDN

Family appliances - Nominal heat output / Famiglia apparecchi - Potenza termica nominale

Type / Tipo	----		----	----	----
Model / Model	Ecwood Gold 26		----	----	----
Fuel type / Tipo di combustibile	Wood A		----	----	----
Tested o interpolated model Modello testato o interpolato	Tested		----	----	----

Performance / Prestazioni	Unit	Mean value Valore medio		Uncertainty Incertezza		Mean value Valore medio		Uncertainty Incertezza		Mean value Valore medio		Uncertainty Incertezza	
Fuel hourly consumption <i>Consumo orario</i>	kg/h	6,12	----	----	----	----	----	----	----	----	----	----	----
Necessary flue draught <i>Requisiti minimi tiraggio camino</i>	mbar	0,10	----	----	----	----	----	----	----	----	----	----	----
Flue gas temperature <i>Temperatura fumi</i>	°C	101,7	----	----	----	----	----	----	----	----	----	----	----
Flue gas mass flow <i>Portata in massa dei fumi</i>	g/s	15,39	----	----	----	----	----	----	----	----	----	----	----
CO emission at 10% O2 (*) <i>Emissioni di CO al 10% O2</i>	mg/Nm ³	26	----	----	----	----	----	----	----	----	----	----	----
Dust emission at 10% O2 (*) <i>Emissioni di polveri al 10% O2</i>	mg/Nm ³	20	----	----	----	----	----	----	----	----	----	----	----
OGC emission at 10% O2 (*) <i>Emissioni di OGC al 10% O2</i>	mg/Nm ³	1	----	----	----	----	----	----	----	----	----	----	----
NOx emission at 10% O2 (*) <i>Emissioni di NOx al 10% O2</i>	mg/Nm ³	151	----	----	----	----	----	----	----	----	----	----	----
Heat input <i>Potenza al focolaio</i>	kW	26,4	----	----	----	----	----	----	----	----	----	----	----
Nominal heat output <i>Potenza termica nominale</i>	kW	24,3	----	----	----	----	----	----	----	----	----	----	----
Declared Nominal heat output <i>Potenza termica nominale dichiarata</i>	kW	26,0	----	----	----	----	----	----	----	----	----	----	----
Measured boiler efficiency (*) <i>Rendimento della caldaia misurato (*)</i>	%	92,2	----	----	----	----	----	----	----	----	----	----	----
Declared boiler efficiency <i>Rendimento della caldaia dichiarato</i>	%	92,2	----	----	----	----	----	----	----	----	----	----	----

(*) = Test results have been estimated with repeatability standard deviation - for models tested

The measurement uncertainties reported in this document have been estimated as expanded uncertainty obtained multiplying the standard uncertainty by the coverage factor K=2 corresponding to a confidence level of about 95% - for models tested

Standard	Test Report No. / Report N°	CS22-0083295-02	Chapter / Capitolo	T11
EN 303-5:2012	Issued on / Emesso il	25.11.2022	Subchapter / Sottocapitolo	TDN

Family appliances - Nominal heat output / Famiglia apparecchi - Potenza termica nominale

Type / Tipo	----	----	----	----	----
Model / Model	Ecwood Gold 26	----	----	----	----
Fuel type / Tipo di combustibile	Wood A	----	----	----	----
Tested o interpolated model Modello testato o interpolato	Tested	----	----	----	----

Emissions / Emissioni	Unit	Mean value Valore medio		Uncertainty Incertezza		Mean value Valore medio		Uncertainty Incertezza		Mean value Valore medio		Uncertainty Incertezza		Mean value Valore medio		Uncertainty Incertezza	
Water operating pressure Pressione di esercizio	bar	1,5	----	----	----	----	----	----	----	----	----	----	----	----	----	----	----
Maximum water operating pressure Pressione massima d'esercizio	bar	3	----	----	----	----	----	----	----	----	----	----	----	----	----	----	----
Max water operating temperature Temperatura massima di esercizio	°C	95	----	----	----	----	----	----	----	----	----	----	----	----	----	----	----
Waterside resistance $\Delta t = 10K$ Resistenza lato acqua $\Delta t = 10K$	mbar	4,8	----	----	----	----	----	----	----	----	----	----	----	----	----	----	----
Waterside resistance $\Delta t = 20K$ Resistenza lato acqua $\Delta t = 20K$	mbar	1,2	----	----	----	----	----	----	----	----	----	----	----	----	----	----	----
Leakage test Perdita lato fumi	m ³ /h	9,8	----	----	----	----	----	----	----	----	----	----	----	----	----	----	----
Electrical power supply Potenza elettrica assorbita	W	57	----	----	----	----	----	----	----	----	----	----	----	----	----	----	----
Rated voltage Tensione nominale	V	230	----	----	----	----	----	----	----	----	----	----	----	----	----	----	----
Rated frequency Frequenza nominale	Hz	50	----	----	----	----	----	----	----	----	----	----	----	----	----	----	----

Class / Classe	Unit	Class	Class	Class	Class	Class
Boiler class Classe della caldaia		5				

(*) = Test results have been estimated with repeatability standard deviation - for models tested
The measurement uncertainties reported in this document have been estimated as expanded uncertainty obtained multiplying the standard uncertainty by the coverage factor K=2 corresponding to a confidence level of about 95% - for models tested

Standard	Test Report No. / Report N°	CS22-0083295-02	Chapter / Capitolo	TI1
EN 303-5:2012	Issued on / Emesso il	25.11.2022	Subchapter / Sottocapitolo	TDR

Family appliances - Reduced heat output / Famiglia apparecchi - Potenza termica ridotta

Type / Tipo	----	----	----	----	----
Model / Model	Ecowood Gold 26	----	----	----	----
Fuel type / Tipo di combustibile	Wood A	----	----	----	----
Tested o interpolated model Modello testato o interpolato	Tested	----	----	----	----

Performance / Prestazioni	Unit	Mean value Valore medio		Uncertainty Incertezza		Mean value Valore medio		Uncertainty Incertezza		Mean value Valore medio		Uncertainty Incertezza	
Fuel hourly consumption <i>Consumo orario</i>	kg/h	3,19	----	----	----	----	----	----	----	----	----	----	----
Necessary flue draught <i>Requisiti minimi tiraggio camino</i>	mbar	0,053	----	----	----	----	----	----	----	----	----	----	----
Flue gas temperature <i>Temperatura fumi</i>	°C	65,2	----	----	----	----	----	----	----	----	----	----	----
Flue gas mass flow <i>Portata in massa dei fumi</i>	g/s	9,7	----	----	----	----	----	----	----	----	----	----	----
CO emission at 10% O2 (*) <i>Emissioni di CO al 10% O2</i>	mg/Nm ³	173	----	----	----	----	----	----	----	----	----	----	----
Dust emission at 10% O2 (*) <i>Emissioni di polveri al 10% O2</i>	mg/Nm ³	3	----	----	----	----	----	----	----	----	----	----	----
OGC emission at 10% O2 (*) <i>Emissioni di OGC al 10% O2</i>	mg/Nm ³	4	----	----	----	----	----	----	----	----	----	----	----
NOx emission at 10% O2 (*) <i>Emissioni di NOx al 10% O2</i>	mg/Nm ³	105	----	----	----	----	----	----	----	----	----	----	----
Heat input <i>Potenza al focolaio</i>	kW	13,8	----	----	----	----	----	----	----	----	----	----	----
Nominal heat output <i>Potenza termica nominale</i>	kW	12,7	----	----	----	----	----	----	----	----	----	----	----
Declared Nominal heat output <i>Potenza termica nominale dichiarata</i>	kW	12,7	----	----	----	----	----	----	----	----	----	----	----
Measured boiler efficiency (*) <i>Rendimento della caldaia misurato (*)</i>	%	92,2	----	----	----	----	----	----	----	----	----	----	----
Declared boiler efficiency <i>Rendimento della caldaia dichiarato</i>	%	92,2	----	----	----	----	----	----	----	----	----	----	----

(*) = Test results have been estimated with repeatability standard deviation - for models tested

The measurement uncertainties reported in this document have been estimated as expanded uncertainty obtained multiplying the standard uncertainty by the coverage factor K=2 corresponding to a confidence level of about 95% - for models tested

Standard	Test Report No. / Report N°	CS22-0083295-02	Chapter / Capitolo	TI1
EN 303-5:2012	Issued on / Emesso il	25.11.2022	Subchapter / Sottocapitolo	TDR

Family appliances - Reduced heat output / Famiglia apparecchi - Potenza termica ridotta

Type / Tipo	----	----	----	----	----
Model / Model	Ecwood Gold 26	----	----	----	----
Fuel type / Tipo di combustibile	Wood A	----	----	----	----
Tested o interpolated model Modello testato o interpolato	Tested	----	----	----	----

Emissions / Emissioni	Unit	Mean value Valore medio		Uncertainty Incertezza		Mean value Valore medio		Uncertainty Incertezza		Mean value Valore medio		Uncertainty Incertezza		Mean value Valore medio		Uncertainty Incertezza	
Water operating pressure Pressione di esercizio	bar	1,5	----	----	----	----	----	----	----	----	----	----	----	----	----	----	----
Maximum water operating pressure Pressione massima d'esercizio	bar	3	----	----	----	----	----	----	----	----	----	----	----	----	----	----	----
Max water operating temperature Temperatura massima di esercizio	°C	95	----	----	----	----	----	----	----	----	----	----	----	----	----	----	----
Waterside resistance $\Delta t = 10K$ Resistenza lato acqua $\Delta t = 10K$	mbar	----	----	----	----	----	----	----	----	----	----	----	----	----	----	----	----
Waterside resistance $\Delta t = 20K$ Resistenza lato acqua $\Delta t = 20K$	mbar	----	----	----	----	----	----	----	----	----	----	----	----	----	----	----	----
Leakage test Perdita lato fumi	m ³ /h	----	----	----	----	----	----	----	----	----	----	----	----	----	----	----	----
Electrical power supply Potenza elettrica assorbita	W	54	----	----	----	----	----	----	----	----	----	----	----	----	----	----	----
Rated voltage Tensione nominale	V	230	----	----	----	----	----	----	----	----	----	----	----	----	----	----	----
Rated frequency Frequenza nominale	Hz	50	----	----	----	----	----	----	----	----	----	----	----	----	----	----	----

Class / Classe	Unit	Class	Class	Class	Class	Class
Boiler class Classe della caldaia		5				

(*) = Test results have been estimated with repeatability standard deviation - for models tested
The measurement uncertainties reported in this document have been estimated as expanded uncertainty obtained multiplying the standard uncertainty by the coverage factor K=2 corresponding to a confidence level of about 95% - for models tested

Standard	Test Report No. / Report N°	CS22-0083295-02	Chapter / Capitolo	T11
EN 303-5:2012	Issued on / Emesso il	25.11.2022	Subchapter / Sottocapitolo	RN

Remarks & Notes

Osservazioni & Note

Continuous heat output for all models

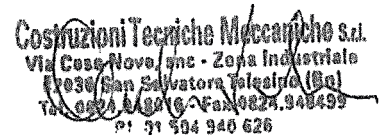
EN 303-5 – Technical details <i>EN 303-5 – Scheda tecnica</i>	
Type of appliance: <i>Tipo di apparecchio:</i>	Heating boilers for solid fuels, manually and automatically stocked, nominal heat output up to 500 kW <i>Caldaje a combustibile solido, alimentate manualmente o automaticamente, con potenza termica nominale fino a 500 kW</i>
Type: <i>Tipo:</i>	Wood gasification boiler- manual loading Caldaia a legna a gassificazione – caricamento manuale
Model: <i>Modello:</i>	ECOWOOD GOLD 26
Manufacturer contact information: <i>Contatti del costruttore:</i>	
Name of manufacturer: <i>Nome del costruttore:</i>	Costruzioni Tecniche Meccaniche S.r.l.
Address of the manufacturer: <i>Indirizzo del costruttore:</i>	Via Cese Nove s.n.c. – Zona Industriale 82030 San Salvatore Telesino (BN) – ITALIA
Trademark: <i>Marchio commerciale:</i>	CTM
Telephone no.: <i>Numero di telefono:</i>	+39 0824948016
Fax no.: <i>Numero di fax:</i>	+39 0824948499
E-mail:	info@ctm-italia.it
Countries in which the product will be marketed: <i>Paesi di commercializzazione del prodotto:</i>	CE - Italy
Basis of Initial Type Testing: <i>Norme di riferimento per prove ITT:</i>	<input checked="" type="checkbox"/> EN 303-5 <input checked="" type="checkbox"/> CEN/TS 15883 (German emission test method) <input checked="" type="checkbox"/> EN 15456
Contact person: <i>Persona di riferimento:</i>	Andrea Pedicini
In the capacity of position in the company: <i>Nella funzione di:</i>	Legal Representative – Amministratore Unico
Date <i>Date</i>	Signature <i>Firma</i>
22/11/2022	 <p>Costruzioni Tecniche Meccaniche S.r.l. Via Cese Nove, snc - Zona Industriale 82030 San Salvatore Telesino (BN) Tel. 0824 948016 - Fax 0824 948499 P.I. 01 904 940 626</p>

Costruzioni Tecniche Meccaniche S.r.l.

Via Cese Nove, Zona Industriale - 82030 San Salvatore Telesino BN - Italy
Tel./Ph.: +39 0824 975507 - +39 0824 948016 - Fax: +39 0824 948499
E-mail: info@ctm-italia.it - www.ctm-italia.it

EN 303-5 – Technical details <i>EN 303-5 – Scheda tecnica</i>	
Type of appliance: <i>Tipo di apparecchio:</i>	Heating boilers for solid fuels, manually and automatically stocked, nominal heat output up to 500 kW <i>Caldaie a combustibile solido, alimentate manualmente o automaticamente, con potenza termica nominale fino a 500 kW</i>
Type: <i>Tipo:</i>	Wood gasification boiler- manual loading Caldaia a legna a gassificazione – caricamento manuale
Model: <i>Modello:</i>	ECOWOOD GOLD 26

Appliance picture
Foto dell'apparecchio



Costruzioni Tecniche Meccaniche S.r.l.

Via Cese Nove, Zona Industriale - 82030 San Salvatore Telesino BN - Italy
Tel./Ph.: +39 0824 975507 - +39 0824 948016 - Fax: +39 0824 948499
E-mail: info@ctm-italia.it - www.ctm-italia.it

EN 303-5 – Technical details <i>EN 303-5 – Scheda tecnica</i>	
Type of appliance: <i>Tipo di apparecchio:</i>	Heating boilers for solid fuels, manually and automatically stocked, nominal heat output up to 500 kW <i>Caldaie a combustibile solido, alimentate manualmente o automaticamente, con potenza termica nominale fino a 500 kW</i>
Type: <i>Tipo:</i>	Wood gasification boiler- manual loading Caldaia a legna a gassificazione – caricamento manuale
Model: <i>Modello:</i>	ECOWOOD GOLD 26

Description of the appliance: <i>Descrizione dell'apparecchio:</i>	Type, installation, intended use, fuel <i>Tipo, installazione, utilizzo, combustibile</i>
Appliance type: <i>Tipo di apparecchio</i>	<input checked="" type="checkbox"/> Heating boiler manually stocked / <i>Caldaia a caricamento manuale</i> <input type="checkbox"/> Heating boiler automatically stocked / <i>Caldaia a caricamento automatico</i>
Testing fuels: <i>Combustibili di prova:</i>	Wood <i>Legno</i>
Chimney flues: <i>Sistema canna fumaria:</i>	<input checked="" type="checkbox"/> Single-flue / <i>Canna fumaria singola</i> <input type="checkbox"/> Shared flue system possible / <i>Sistema canna fumaria condivisa</i>
Boiler designed to operate on a: <i>Caldaia progettata per funzionare in:</i>	<input type="checkbox"/> open system / <i>un impianto a vaso di espansione aperto</i> <input type="checkbox"/> sealed system / <i>un impianto a vaso di espansione chiuso</i>

Description of the appliance: <i>Descrizione dell'apparecchio:</i>	Principal dimensions <i>Dimensioni principali</i>	
Weight without water: <i>Peso a secco:</i>	kg	440
External dimensions: <i>Dimensioni esterne:</i>	Width: <i>Larghezza:</i>	714
	Depth: <i>Profondità:</i>	897
	Height: <i>Altezza:</i>	1200
Flue spigot/socket diameter Ø: <i>Diametro raccordo fumi Ø:</i>	mm	150
Surface area of the firebox: <i>Dimensioni area piano fuoco:</i>	mm / m ²	0,2016
Retort size: <i>Dimensioni crogiolo:</i>	mm	360x560
Free retort area: <i>Superficie libera crogiolo:</i>	mm ²	0,0066

Hopper: <i>Tramoggia:</i>	Internal: <i>Integrato</i>	m ³	---
	External: <i>Esterno</i>	m ³	---
Pump supplied <i>Circolatore in dotazione</i>		W	---
EN 303-5 – Technical details <i>EN 303-5 – Scheda tecnica</i>			
Type of appliance: <i>Tipo di apparecchio:</i>	Heating boilers for solid fuels, manually and automatically stocked, nominal heat output up to 500 kW <i>Caldaie a combustibile solido, alimentate manualmente o automaticamente, con potenza termica nominale fino a 500 kW</i>		
Type: <i>Tipo:</i>	Wood gasification boiler- manual loading <i>Caldaia a legna a gassificazione – caricamento manuale</i>		
Model: <i>Modello:</i>	ECOWOOD GOLD 26		

Appliance construction materials: <i>Materiali di costruzione dell'apparecchio:</i>		
Components:	Material	Designation of material
Combustion chamber materials: <i>Materiali della camera di combustione:</i>	<input checked="" type="checkbox"/> Steel / <i>Acciaio</i>	S355J2WC (COR-TEN B) EN10025-5
	<input type="checkbox"/> Cast iron / <i>Ghisa</i>	
	<input type="checkbox"/> Vermiculite / <i>Vermiculite</i>	
	<input checked="" type="checkbox"/> Firebrick / <i>Mattone refrattario</i>	
Boiler materials: <i>Materiali della caldaia:</i>	<input checked="" type="checkbox"/> Steel / <i>Acciaio</i>	S355J2WC (COR-TEN B) EN10025-5
	<input type="checkbox"/> Cast iron / <i>Ghisa</i>	
Inspection glass: <i>Vetro ispezione focolare:</i>	<input checked="" type="checkbox"/> Ceramic glass / <i>Vetro ceramico</i>	Vetro ceramico temperato
Seal materials: <i>Materiali di tenuta:</i>	<input checked="" type="checkbox"/> Basket / <i>Guarnizione</i>	Filo di vetro
	<input type="checkbox"/> Fire-cement / <i>Cemento refrattario</i>	
	<input type="checkbox"/> Other / <i>Altro</i>	
Lagging material: <i>Isolamento termico:</i>	<input type="checkbox"/> Other / <i>Altro</i>	Feltro lamellare 50 SP 30
Other: <i>Altro:</i>	<input type="checkbox"/> Other / <i>Altro</i>	

Costruzioni Tecniche Meccaniche S.r.l.

EN 303-5 – Technical details <i>EN 303-5 – Scheda tecnica</i>	
Type of appliance: <i>Tipo di apparecchio:</i>	Heating boilers for solid fuels, manually and automatically stocked, nominal heat output up to 500 kW <i>Caldaie a combustibile solido, alimentate manualmente o automaticamente, con potenza termica nominale fino a 500 kW</i>
Type: <i>Tipo:</i>	Wood gasification boiler- manual loading <i>Caldaia a legna a gassificazione – caricamento manuale</i>
Model: <i>Modello:</i>	ECOWOOD GOLD 26
Appliance accessories and equipments: <i>Accessori e dotazioni dell'apparecchio:</i>	
Operating tools: <i>Attrezzi operativi:</i>	<input type="checkbox"/> Glove / <i>Guanto ignifugo</i>
	<input type="checkbox"/> Flueways cleaning tool / <i>Mezzo per la pulizia del giro fumi</i>
	<input checked="" type="checkbox"/> Ashpan / <i>Cassetto cenere</i>
	<input type="checkbox"/> Ash removal / <i>Mezzo per la rimozione della cenere</i>
	<input type="checkbox"/> Other / <i>Specificare</i>
	<input type="checkbox"/> Other / <i>Specificare</i>
	<input type="checkbox"/> Other / <i>Specificare</i>
Appliance installation: <i>Installazione dell'apparecchio:</i>	
Permitted installation on flammable floor <i>Installabile su pavimento infiammabile</i>	No
Roomheater to floor: <i>Distanza minima in aria da pavimento infiammabile:</i>	mm ---
Designation of requested chimney <i>Designazione canna fumaria da utilizzare</i>	
Other: <i>Altro:</i>	

EN 303-5 – Technical details <i>EN 303-5 – Scheda tecnica</i>	
Type of appliance: <i>Tipo di apparecchio:</i>	Heating boilers for solid fuels, manually and automatically stocked, nominal heat output up to 500 kW <i>Caldaie a combustibile solido, alimentate manualmente o automaticamente, con potenza termica nominale fino a 500 kW</i>
Type: <i>Tipo:</i>	Wood gasification boiler- manual loading Caldaia a legna a gassificazione – caricamento manuale
Model: <i>Modello:</i>	ECOWOOD GOLD 26

Technical data of the appliance: <i>Dati tecnici dell'apparecchio:</i>			
Designation: <i>Designazione:</i>		Nominal heat output <i>Potenza termica nominale</i>	Reduced heat output <i>Potenza termica ridotta</i> <input checked="" type="checkbox"/> Continuous <input type="checkbox"/> Intermittent
Fuel throughput <i>Consumo orario</i>	Kg/h	6,118	3,19
Necessary flue draught <i>Requisiti minimi del tiraggio del camino</i>	Pa	10,2	5,3
Flue gas temperature <i>Temperatura fumi</i>	°C	120	100
Flue gas mass flow <i>Flusso massico dei fumi</i>	g/s	0,01528	0,00969
Nominal heat output <i>Potenza termica nominale</i>	kW	26	12,7
Efficiency <i>Rendimento</i>	%	91,3	92,2
CO emission at 10% of O₂ <i>Emissioni di CO al 10% di O₂</i>	mg/Nm ³	26	173
OGC emission at 10% of O₂ <i>Emissioni di OGC al 10% di O₂</i>	mg/Nm ³	1	4
NO_x emission at 10% of O₂ <i>Emissioni di NO_x al 10% di O₂</i>	mg/Nm ³	136	105
DUST emission at 10% of O₂ <i>Emissioni di Particolato al 10% di O₂</i>	mg/Nm ³	20	3
Maximum water operating pressure <i>Massima pressione di esercizio dell'acqua</i>	Bar	3	3
Boiler Class <i>Classe della caldaia</i>		5	5
Accumulator storage <i>Serbatoio d'accumulo calore in eccesso</i>	lt	55	55
Electrical power supply <i>Potenza elettrica assorbita</i>	W		
Rated voltage <i>Tensione nominale</i>	V	230	230
Rated frequency <i>Frequenza nominale</i>	Hz	50	50

Costruzioni Tecniche Meccaniche S.r.l.